

## Series

- ① = Series E (economy – on plinths)
- ② = Series CF (C-frame – mobile underbench units)
- ③ = Series H (suspended underbench units)
- ④ = Series 4-leg frame (mobile underbench units)
- ⑤ = Series CL (Cantilever – wall mounted)
- ⑥ = Series CL (Cantilever – free-standing)
- ⑦ = C-section frame
- ⑧ = 4-leg frame



Melamine top, PP ridge



Stainless steel top



Phenolic resin



Polypropylene top

## Worktops

### Other worktops

- Epoxy resin top
- Tiled top
- Phenolic resin top with formed epoxy resin marine edge
- Solid wood top (beech)
- Multiplex top
- Melamine resin postformed top

Stoneware top



Composite stoneware top



Glass top,  
epoxy resin marine edge

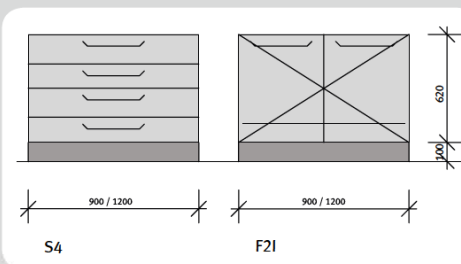
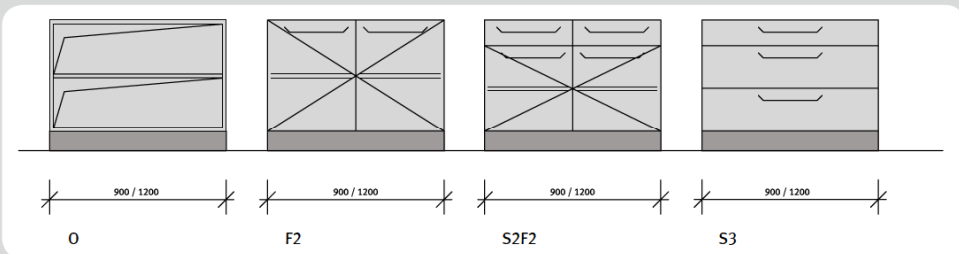
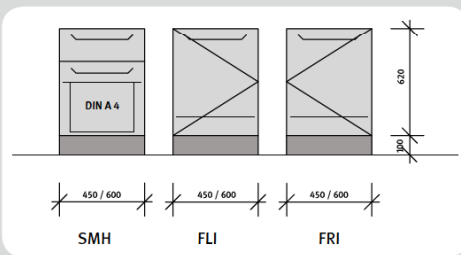
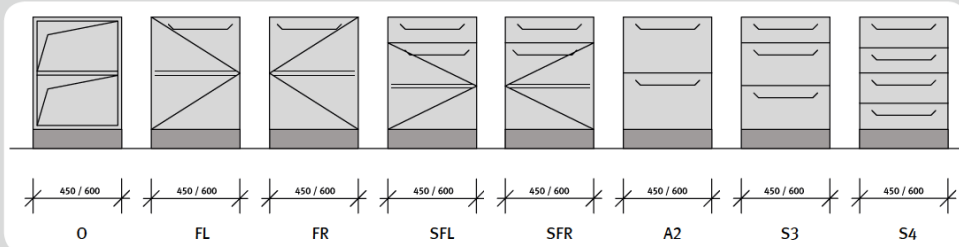

## Underbench cabinets

Seated working height 750 mm  
 Depth of underbench units 500 / 600 mm  
 Height of plinths 100 mm

- O = Open
- FL = Door left
- FR = Door right
- SFL = Drawer, door left
- SFR = Drawer, door right
- A2 = 2 telescopic drawers
- S3 = 3 drawers
- S4 = 4 drawers
- SMH = Drawer, material drawer, file drawer with hangers
- FLI = Sink cabinet, door left
- FRI = Sink cabinet, door right
- F2 = 2 doors
- S2F2 = 2 drawers, 2 doors
- F2I = Sink cabinet, 2 doors

• Option: label holder for loop handle system

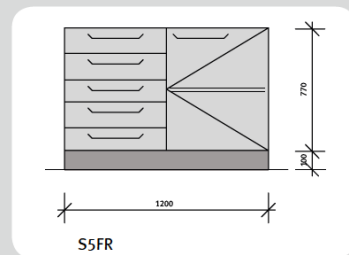
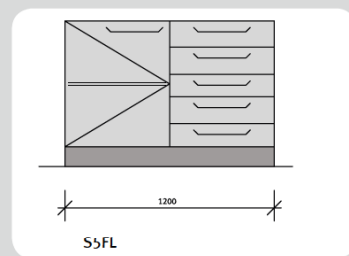
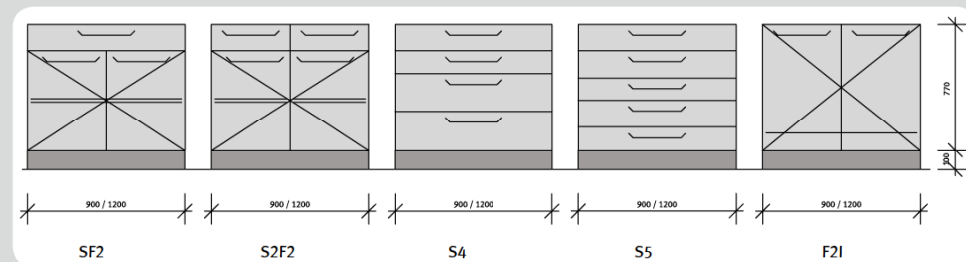
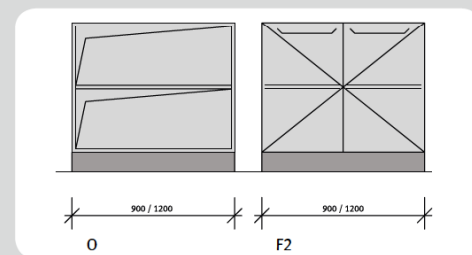
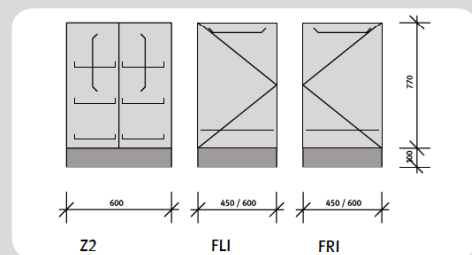
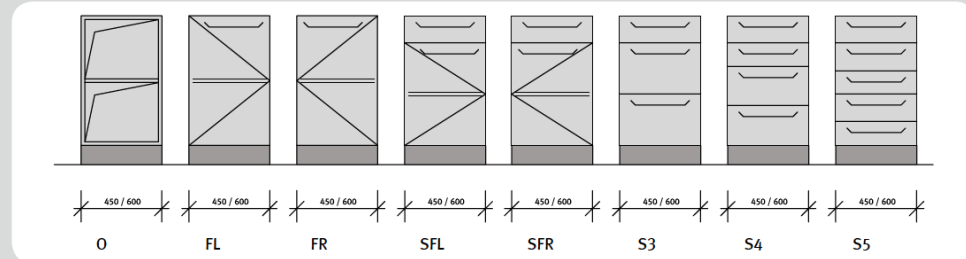

## Underbench cabinets

Standing working height 900 mm  
 Depth of underbench 500 / 600 mm  
 Height of plinths 100 mm

- O = Open
  - FL = Door left
  - FR = Door right
  - SFL = Drawer, door left
  - SFR = Drawer, door right
  - S3 = 3 drawers
  - S4 = 4 drawers
  - S5 = 5 drawers
  - Z2 = 2 cabinet drawers
  - FLI = Sink cabinet, door left
  - FRI = Sink cabinet, door right
  - F2 = 2 doors
  - SF2 = drawer, 2 doors
  - S2F2 = 2 drawers, 2 doors
  - F2I = Sink cabinet, 2 doors
  - S5FL = 5 drawers, door left
  - S5FR = 5 drawers, door right
- Option: label holder for loop handle system

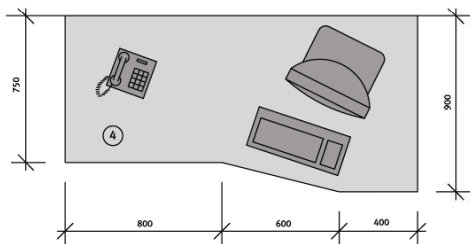
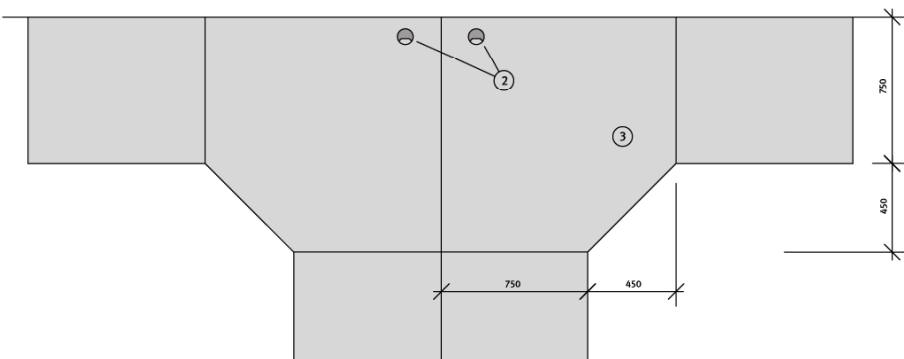
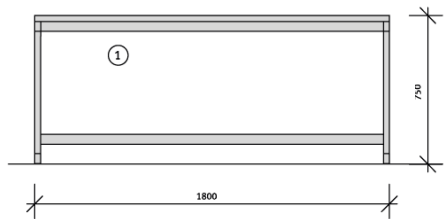
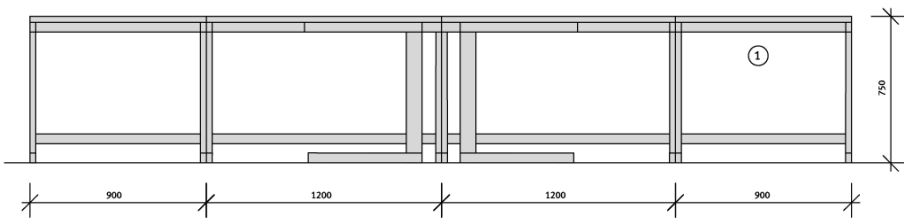

- ① = C-section frame and/or C-section frame height adjustable
- ② = Option: cable port  $\varnothing$  80 mm
- ③ = Corner tops in various dimensions for desk workplace
- ④ = Ergo workplace



## Desk workplaces

- Work tables for sitting, optionally with height adjustable table base
- Electric terminals, telephone sockets and data links inside the system channel to the side or back of the table
- System channel as an option with integrated convection grid
- Table corner solution with VDU workplace
- Underbench framework as fixed or flexible solution with mobile elements
- Various table depths available
- Because of the function grooves in the system channel an extensive range of accessories for organizing the worktops is available